

Carlton® Bore-Gard® and Boreable Multi-Gard® Raceway

*Bore-Gard
Schedule 40*

*Bore-Gard
Schedule 80*

*Boreable
Multi-Gard
Type 40*

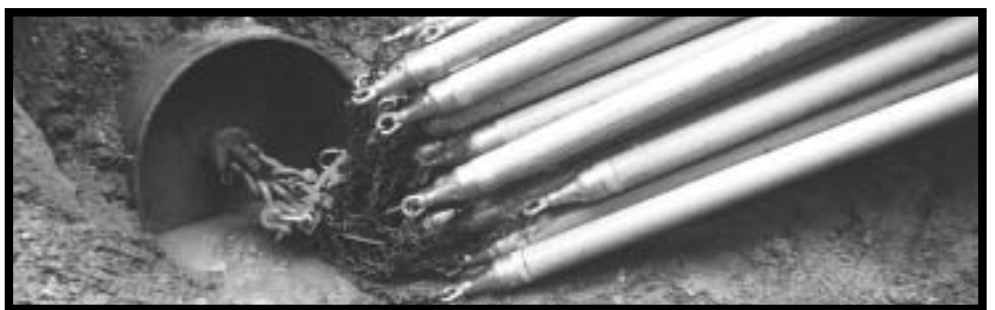

Carlton® Bore-Gard® Trenchless Raceway

Carlton's PVC Bore-Gard conduit eliminates the costly problems of HDPE pipe on a reel such as reel handling, fusion welding, uncoiling and wasted pipe, safety hazards and additional job site labor.

Bore-Gard is designed and proven to meet the rigorous requirements of horizontal directional drilling for electrical and datacom applications and is available in Heavywall Schedule 40 or Extra Heavywall Schedule 80 conduit.

The unique design incorporates a water-tight seal and locking ring that enables fast, cement-free assembly, strong enough for 1000 foot bores. Short lengths of 10 and 20 feet fit into the tightest spaces and can be easily transported to the job site. Simplify trenchless installations and lower your costs with Bore-Gard.

RUS Listed

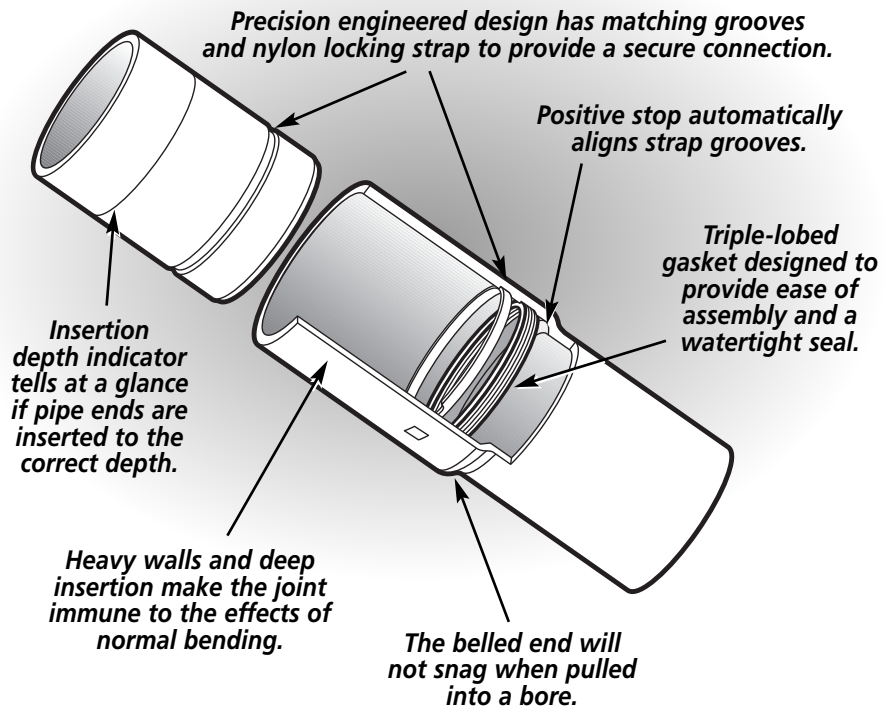

Features:

- Easy to handle 10 and 20 foot lengths
- For bores up to 1000 feet
- Fast easy assembly
- Strong water-tight joints without cement
- Fits standard rigid nonmetallic conduit fittings
- All nonmetallic construction
- Superior crush and stiffness over HDPE
- Eliminates the need for chains and backing plate installation
- Type: Schedule 40 - Heavywall Schedule 80 - Extra Heavywall
- Sizes: Schedule 40 - 3", 4", 5", & 6" Schedule 80 - 3" & 4"



Locking ring enables fast, cement-free assembly.



Slide locking ring into the joint.



Fully assembled, the locking ring provides strong water-tight joints without cement.

Carlton® Boreable Multi-Gard®

Carlton's PVC Boreable Multi-Gard conduit combines a strong boreable outerduct with the convenience of a Multi-Cell conduit.

Boreable Multi-Gard utilizes leading technology from Carlton's PVC Bore-Gard® Trenchless Raceway, offering a field-proven design.

Bores up to 500 feet can be achieved without labor-intensive operations. Lengths of 20 feet fit into tight spaces often encountered on underground boring job sites.

Experience the strength and convenience of Carlton Boreable Multi-Gard.

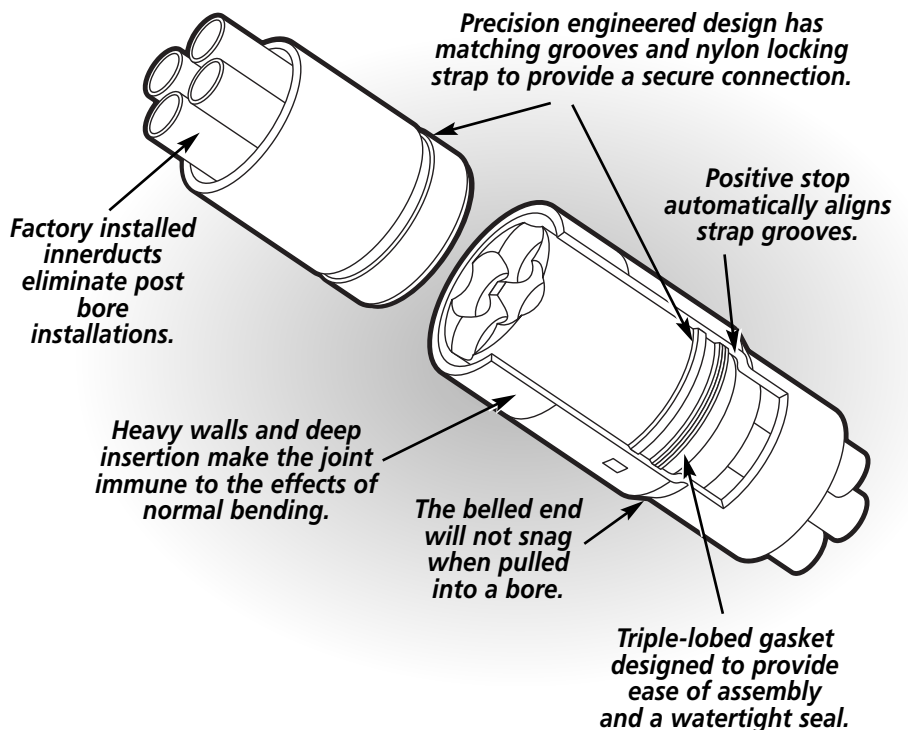

Features:

- Withstands pulling and bending forces of directional drilling
- Fast assembly
- Eliminates labor related to gluing and screwing joints together
- For bores up to 500 feet
- Innerducts: 3-way or 4-way
- Easy to handle 20 foot lengths
- Type: Type 40 PVC outerduct
- Size: 4"
- Prelubricated innerducts
- Strong water-tight joints without cement
- Fits standard Schedule 40 fittings
- Compatible with Multi-Gard Type 40 PVC products



Factory installed innerducts provide immediate post bore cable installation



Designed to meet all your cable needs.

Statue of Liberty



Carlton® Bore-Gard® was the product of choice when additional conduit was considered necessary for future utilities and cables on Liberty Island.



Horizontal Directional Drilling was the preferred method of installation because it minimized any disruption to the island's pristine environment.



Bore-Gard is a PVC trenchless raceway specifically designed for Horizontal Directional Drilling. Bore-Gard is seal rated for 75psi, keeping drilling fluid and underground water out. It has a strong, cement-free joint, making installations fast and easy. It comes in convenient 10 ft. and 20 ft. lengths and is strong enough for 1000 ft. bores.



Bore-Gard® Assembly



Trim spigot end before attaching pulling eye.



Tighten pulling eye so that it expands against interior of the conduit.



Attach the next piece of Bore-Gard.

1. Position Bore-Gard with the print line facing up.
2. Remove plastic locking strap and set it aside.
3. Remove end caps. On first stick only, trim spigot end of Bore-Gard at the groove before attaching the pulling eye/gripping attachment.
4. Insert pulling eye into spigot end of Bore-Gard.
5. Tighten pulling eye so that it expands against the interior of the conduit. Use of sleeve over O.D. of conduit is recommended.
6. The installer should use appropriate instrumentation to insure that maximum pull rating is not exceeded.
7. Take next piece of Bore-Gard (10' or 20') and insert spigot end into belled end of the first piece until the insertion line is no longer visible.
8. Slide the plastic locking strap into slot on the side of the bell. Push the strap in completely. It is not necessary to remove or cover the handle on the strap.
9. Repeat with remaining sections as space allows.
10. Bore-Gard is now ready for installation.

For additional information on the Bore-Gard® line of products, request Frequently Asked Questions about Bore-Gard, BGFAQ; Bore-Gard Technical Reference Guide, BGTRG; Ten Reasons to Buy Bore-Gard, BG10REA and the Bore-Gard six minute Video, BGVID. All of these materials are available direct from Carlon or from your local Carlon representative.

Boreable Multi-Gard® Assembly

1. Position Boreable Multi-Gard with the print line facing up.
2. Remove plastic locking strap and set it aside.
3. Seal off lead end to keep out drilling fluid.
4. Attach 4" Kellems Grip over lead end.
Note: Internal pulling eye cannot be used due to innerduct interference.
5. The installer should use appropriate instrumentation to insure that the maximum pull rating is not exceeded.
6. Take next piece of Boreable Multi-Gard and insert spigot end into belled end of the first piece until the insertion line is no longer visible.
NOTE: Innerducts need to be aligned before insertion
7. Slide the plastic locking strap into slot on the side of the bell. Push strap in completely. It is not necessary to remove or cover the handle on the strap.
8. Repeat with remaining sections as space allows.
9. Pull into bored hole. Terminate into man holes.
10. Boreable Multi-Gard is now ready for duct proofing and cable installation.

For more information on Carlon's Multi-Gard® System, request catalog number 2B21.

Bend Radius for Bore-Gard® & Boreable Multi-Gard®

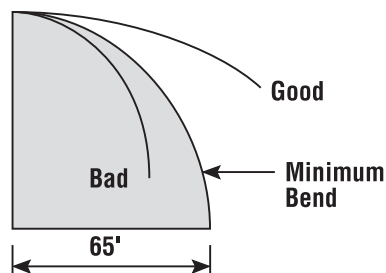

Minimum Bend Radius: Turns in a bore path should be made gradually. Bore-Gard and Boreable Multi-Gard have a minimum bend radius of 65'. Bending more than this recommended limit will stress the joint. The drawing below illustrates the 65' bend radius. To obtain a 90° turn you will require 65' of forward distance in any directional plane.

Note: Successful directional drilling, reaming and pipe installation are influenced by numerous factors including the reamed diameter, pull rate, fluid chemistry, fluid flow rate, drill rod diameter, soil conditions, equipment performance and condition, and operator experience. All manufacturers' equipment recommendations and training should be followed for successful drilling results.



Bore-Gard is flexible enough to be pulled around a building.

Bore-Gard®/Boreable Multi-Gard® Specifications

Bore-Gard® Specifications

*U.S. Patent 6,789,629



LISTED
Except where noted by ▶



Except where noted by †

Schedule 40

• RUS Listed

Part No.	Description	Overall Length (ft.)	Lay Length	Dimensions O.D. (in.)	Dimensions I.D. (in.)	Pkg. Qty. (ft./bundle)	Bundles per Truckload	Feet per Truckload	Wt. per 100 ft. (lbs.)	Min. Bend Radius (ft.)	Insertion Force (lbs.)	Seal Pressure Rating (P.S.I.)	Joint Pull Rating (lbs.)	Typical Crush lbs. (@ 30% deflection)	UL Std. 651 & NEMA TC2 Min. Crush (lbs.)
BG340SP-010	3" Sch. 40 Bore-Gard	10	9'6"	3.50	3.0	350	56	19,600	164	65	20	75	7,000	1,225	1,000
BG340SP-020	3" Sch. 40 Bore-Gard	20	19'6"	3.50	3.0	700	28	19,600	164	65	20	75	7,000	1,225	1,000
BG440SP-010	4" Sch. 40 Bore-Gard	10	9'6"	4.50	4.0	260	56	14,560	234	65	40	75	8,700	1,075	900
BG440SP-020	4" Sch. 40 Bore-Gard	20	19'6"	4.50	4.0	520	28	14,560	234	65	40	75	8,700	1,075	900
BG540SP-010	5" Sch. 40 Bore-Gard	10	9'6"	5.56	5.0	230	40	9,200	317	65	60	75	11,300	950	850
BG540SP-020	5" Sch. 40 Bore-Gard	20	19'6"	5.56	5.0	460	20	9,200	317	65	60	75	11,300	950	850
BG640SP-010	6" Sch. 40 Bore-Gard	10	9'6"	6.625	6.0	200	40	8,000	418	65	80	75	14,000	950	850
BG640SP-020	6" Sch. 40 Bore-Gard	20	19'6"	6.625	6.0	400	20	8,000	418	65	80	75	14,000	950	850

Schedule 80

• RUS Listed

Part No.	Description	Overall Length (ft.)	Lay Length	Dimensions O.D. (in.)	Dimensions I.D. (in.)	Pkg. Qty. (ft./bundle)	Bundles per Truckload	Feet per Truckload	Wt. per 100 ft. (lbs.)	Min. Bend Radius (ft.)	Insertion Force (lbs.)	Seal Pressure Rating (P.S.I.)	Joint Pull Rating (lbs.)	Typical Crush lbs. (@ 30% deflection)	UL Std. 651 & NEMA TC2 Min. Crush (lbs.)
† BG480SP-010	4" Sch. 80 Bore-Gard	10	9'6"	4.50	3.8	260	56	14,560	308	65	40	75	12,000	2,000	2,000
† BG480SP-020	4" Sch. 80 Bore-Gard	20	19'6"	4.50	3.8	520	28	14,560	308	65	40	75	12,000	2,000	2,000
† BG380SP-010	3" Sch. 80 Bore-Gard	10	9'6"	3.50	2.8	350	56	19,600	210	65	20	75	10,000	2,000	2,000
† BG380SP-020	3" Sch. 80 Bore-Gard	20	19'6"	3.50	2.8	700	28	19,600	210	65	20	75	10,000	2,000	2,000

Accessories

Pulling Eyes

These high-quality pulling eyes have a permanent outer sleeve and a seal on pipe O.D.

Part No.	Description	Package Dimensions (in.)	Package Weight (lbs.)	Package Type
▶ BG3PE	3" Pulling Eye	10" x 4" x 4"	8	Carton
▶ BG4PE	4" Pulling Eye	17" x 6" x 6"	26	Carton
▶ BG5PE	5" Pulling Eye	16" x 7 ³ / ₄ " x 7 ³ / ₄ "	37	Crate
▶ BG6PE	6" Pulling Eye	19 ¹ / ₂ " x 8 ¹ / ₄ " x 8 ¹ / ₄ "	63	Crate

Locking Straps

Gaskets

Size	Part No.	Std. Ctn. Qty.	Part No.	Std. Ctn. Qty.
3"	▶ GSUP3	1	▶ HBOR3	1
4"	▶ GSUP	1	▶ HBOR	1
5"	▶ GSUP5	1	▶ HBOR5	1
6"	▶ GSUP6	1	▶ HBOR6	1

Boreable Multi-Gard® Specifications

Part No.	Description	Length (ft.)	Dimensions O.D. (in.)	Innerduct Dimensions I.D. (in.)	Pkg. Qty. (ft./bundle)	Bundles per Truckload	Feet per Truckload	Wt. per 100 ft. (lbs.)	Min. Bend Radius (ft.)	Seal Pressure Rating (P.S.I.)	Maximum Pull Rating (lbs.)
▶ MFSS3B-020	3-way Boreable Multi-Gard	20	4.50	1.50	520	28	14,560	561	65	75	5000
▶ MFSS4B-020	4-way Boreable Multi-Gard	20	4.50	1.19	520	28	14,560	565	65	75	5000

Steel Mesh Grip part no. MAG4 is recommended to be used as pulling attachment for Boreable Multi-Gard®.