



Single Gang FS Boxes

Type FSE

All sizes take standard covers and accessories or devices. Integral mounting feet provide easy mounting.



For dead-end terminations.

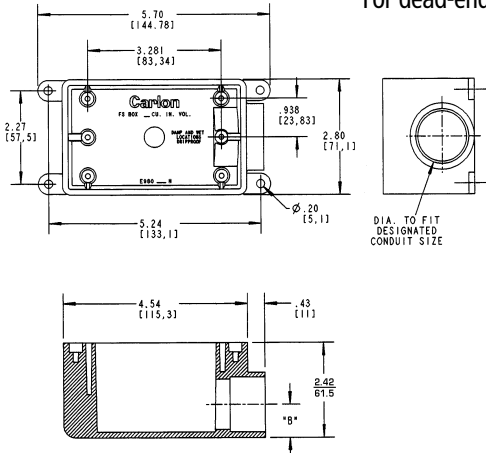

Part No.	Size	Vol. Cu. In.	Std. Ctn. Qty.
E980DFN	1/2	19	10
E980EFN	3/4	19	10
E980FFN	1	19	18
E980FFN-CAR	1	19	10

Type FSC

All sizes take standard covers and accessories or devices. Detachable mounting feet provide easy mounting.



For through terminations.

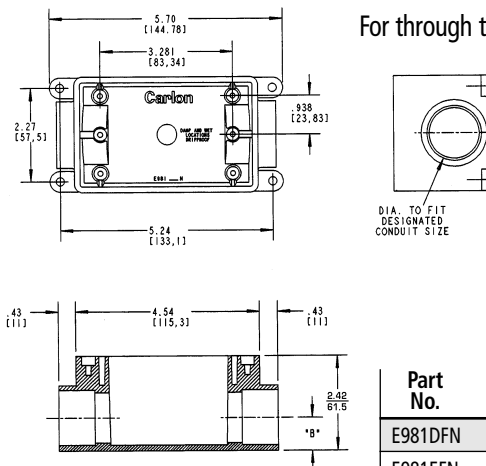

Part No.	Size	Vol. Cu. In.	Std. Ctn. Qty.
E981DFN	1/2	19	15
E981EFN	3/4	19	15
E981FFN	1	19	18
E981FFN-CAR	1	19	10

Type FSS

All sizes take standard covers and accessories or devices. Detachable mounting feet provide easy mounting.

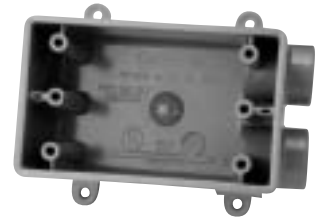

For multiple dead-end circuit terminations or where additional support is required in stub-up applications.

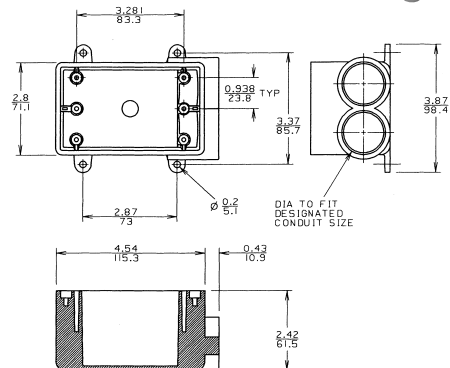

Part No.	Size	Vol. Cu. In.	Std. Ctn. Qty.
E982DFN	1/2	19	10
E982EFN	3/4	19	10
E982FFN-CTN	1	19	8

Type FSCC

All sizes take standard covers and accessories or devices. Detachable mounting feet provide easy mounting.

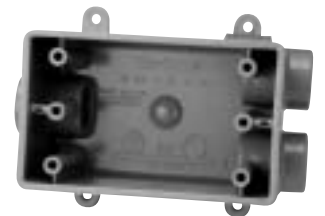

For multiple through circuit terminations or where additional support is required in stub-up applications.

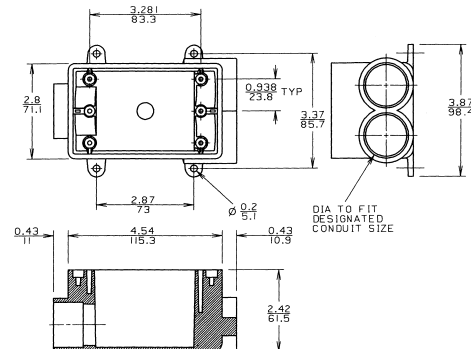

Part No.	Size	Vol. Cu. In.	Std. Ctn. Qty.
E979DFN-CAR	1/2	19	10
E979EFN-CAR	3/4	19	10
E979FFN	1	19	15



Single Gang FD Deep Device Boxes

Type FD

All sizes take standard covers and accessories or devices. Integral mounting feet provide easy mounting.

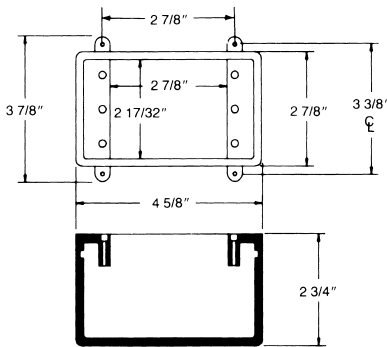
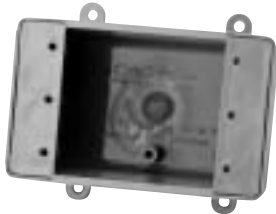

For terminations where hub requirements vary according to application – hubs easily made with flared wood bit or hole saw.

Part No.	Size	Vol. Cu. In.	Std. Ctn. Qty.
E9801	N/A	25	10

Type FDC

All sizes take standard covers and accessories or devices. Integral mounting feet provide easy mounting.

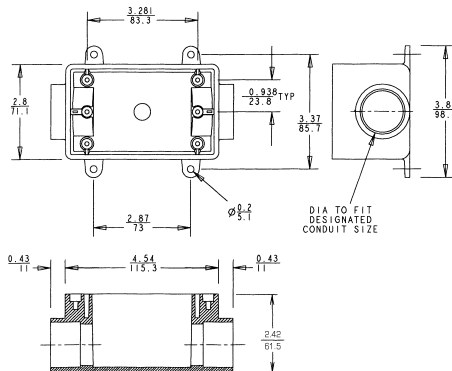
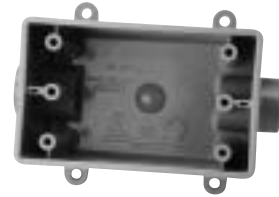

For through terminations where large devices or additional wiring capacity is required.

Part No.	Size	Vol. Cu. In.	Std. Ctn. Qty.
E9811DN	1/2	25	10
E9811EN	3/4	25	10
E9811FN	1	25	10

Type FDE

All sizes take standard covers and accessories or devices. Integral mounting feet provide easy mounting.

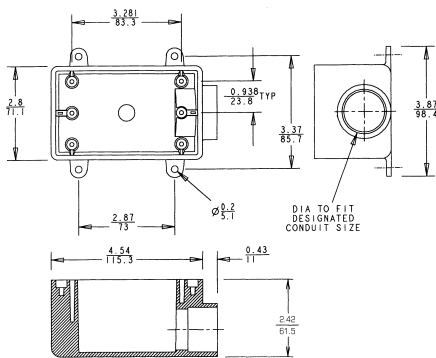
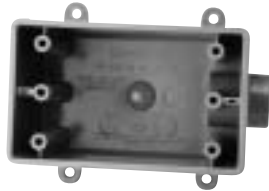

For dead-end terminations where large devices or additional wiring capacity is required.

Part No.	Size	Vol. Cu. In.	Std. Ctn. Qty.
E9801DN	1/2	25	10
E9801EN	3/4	25	10
E9801FN	1	25	10



Two Gang FS Boxes

Type 2FSC

All sizes take standard covers and accessories or devices. Integral mounting feet provide easy mounting.

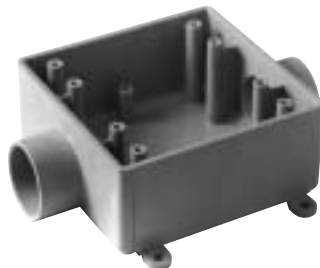

For through terminations where two devices or additional wiring capacity is required.

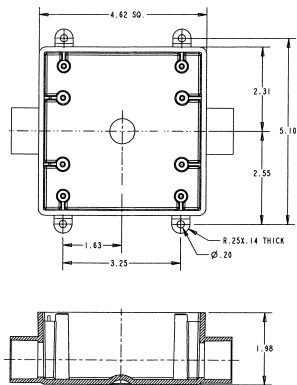

Part No.	Size	Vol. Cu. In.	Std. Ctn. Qty.
E9812D	1/2	32	10
E9812E	3/4	32	10
E9812F	1	32	10

Type 2FSE

All sizes take standard covers and accessories or devices. Integral mounting feet provide easy mounting.

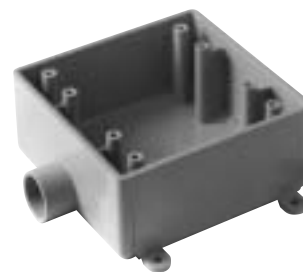

For dead-end terminations where two devices or additional wiring capacity is required.

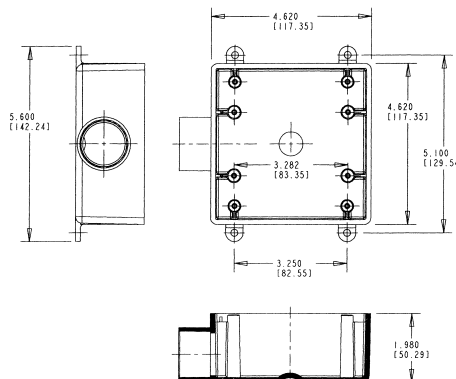

Part No.	Size	Vol. Cu. In.	Std. Ctn. Qty.
E9802D	1/2	32	10
E9802E	3/4	32	10
E9802F	1	32	10

Type FS

All sizes take standard covers and accessories or devices. Integral mounting feet provide easy mounting.



For terminations where hub requirements vary according to application - hubs easily made with flared wood bit or hole saw.

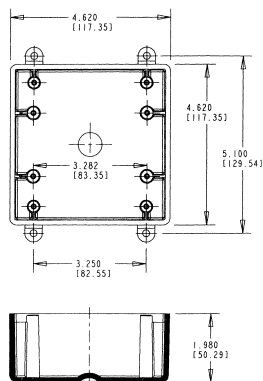

Part No.	Size	Vol. Cu. In.	Std. Ctn. Qty.
E9802	N/A	32	10

Blank Covers

Single Gang



Fits Carlon® single gang FS boxes. Supplied with stainless steel mounting screws and gasket.

Part No.	Color	Std. Ctn. Qty.	Std. Ctn. Wt. (lbs.)
E980CN-CAR	Gray	12	1.60
E980CM-CAR	White	12	1.60

Two Gang



Fits Carlon® two gang FS boxes, other nonmetallic and metallic FS boxes. Supplied with stainless steel mounting screws and gasket.

Part No.	Color	Std. Ctn. Qty.	Std. Ctn. Wt. (lbs.)
E9802CN-CAR	Gray	10	2.17

Corrosion Resistance of Carlon Schedule 40 and Schedule 80 PVC Conduit and Fittings

Carlon Schedule 40 and Schedule 80 are generally acceptable for use in environments containing the chemicals below. These environmental resistance ratings are based upon tests where the specimens were placed in complete submergence in the reagent listed. Schedule 40 and Schedule 80 can be used in many process areas where

chemicals not on this list are manufactured or used because worker safety requirements dictate that any air presence or splashing be at a very low level.

If there are any questions for specific suitability in a given environment, prototype samples should be tested under actual conditions.

Acetic Acid 0-20%	Butyl Alcohol	Fluorine Gas – Wet	Mercurous Nitrate	Sodium Arsenite
Acetic Acid 20-30%	Butyl Phenol	Fluorine Gas – Dry	Mercury	Sodium Benzoate
Acetic Acid 30-60%	Butylene	Fluoroboric Acid	Methyl Sulfate	Sodium Bicarbonate
Acetic Acid 80%	Butyric Acid	Fluorosilicic Acid	Methylene Chloride	Sodium Bisulfate
Acetic Acid – Glacial	Calcium Bisulfite	Formaldehyde	Mineral Oils	Sodium Bisulfite
Acetic Acid Vapors	Calcium Carbonate	Formic Acid	Naphthalene	Sodium Bromide
Acetylene	Calcium Chlorate	Fructose	Nickel Chloride	Sodium Chlorate
Adipic Acid	Calcium Chloride	Gallic Acid	Nickel Nitrate	Sodium Chloride
Alum	Calcium Hydroxide	Gas – Coke Oven	Nitric Acid, Anhydrous	Sodium Cyanide
Aluminum Chloride	Calcium Hypochlorite	Gas – Natural (Dry)	Nitric Acid 20%	Sodium Dichromate
Aluminum Fluoride	Calcium Nitrate	Gas – Natural (Wet)	Nitric Acid 40%	Sodium Ferricyanide
Aluminum Hydroxide	Calcium Sulfate	Gasoline – Sour	Nitric Acid 60%	Sodium Ferrocyanide
Aluminum Oxychloride	Carbonic Acid	Gasoline – Refined	Nitrobenzene	Sodium Fluoride
Aluminum Nitrate	Carbon Dioxide Gas – Wet	Glucose	Nitrous Oxide	Sodium Hydroxide
Aluminum Sulfate	Carbon Dioxide – Aqueous Solution	Glycerine (Glycerol)	Oils and Fats	Sodium Hypochlorite
Ammonia-Dry Gas	Carbon Monoxide	Glycol	Oils – Petroleum – (See Type)	Sodium Nitrate
Ammonium Bifluoride	Caustic Potash	Glycolic Acid	Oleic Acid	Sodium Nitrite
Ammonium Carbonate	Caustic Soda	Green Liquor (Paper Industry)	Oxalic Acid	Sodium Sulfate
Ammonium Chloride	Chloracetic Acid	Heptane	Palmitic Acid 10%	Sodium Sulfide
Ammonium Hydroxide 28%	Chloral Hydrate	Hexanol, Tertiary	Perchloric Acid 10%	Sodium Sulfite
Ammonium Metaphosphate	Chlorine Gas (Dry)	Hydrobromic Acid 20%	Phenylhydrazine Hydrochloride	Sodium Thiosulfate (Hypo)
Ammonium Nitrate	Chlorine Gas (Moist)	Hydrochloric Acid 0% - 25%	Phosgene, Gas	Stannic Chloride
Ammonium Persulfate	Chlorine Water	Hydrochloric Acid 25% - 40%	Phosphoric Acid – 0-25%	Stannous Chloride
Ammonium Phosphate – Neutral	Chlorosulfonic Acid	Hydrocyanic Acid or Hydrogen Cyanide	Phosphoric Acid – 25-50%	Stearic Acid
Ammonium Sulfate	Chrome Alum	Hydrofluoric Acid 10%	Phosphoric Acid – 50-85%	Sulfur
Ammonium Sulfide	Chromic Acid 10%	Hydrofluorosilicic Acid	Photographic Chemicals	Sulfur Dioxide – Gas Dry
Ammonium Thiocyanate	Chromic Acid 30%	Hydrogen Phosphide	Plating Solutions	Sulfur Trioxide
Amyl Alcohol	Chromic Acid 40%	Hydrogen Sulfide – Dry	Potassium Bicarbonate	Sulfuric Acid – 0-10%
Antraquinone	Chromic Acid 50%	Hydrogen Sulfide – Aqueous Solution	Potassium Bichromate	Sulfuric Acid – 10-75%
Antraquinonesulfonic Acid	Citric Acid	Hydroquinone	Potassium Borate	Sulfuric Acid – 75-90%
Antimony Trichloride	Copper Chloride	Hydroxylamine Sulfate	Potassium Bromide	Sulfurous Acid
Aqua Regia	Copper Cyanide	Iodine	Potassium Carbonate	Tannic Acid
Arsenic Acid 80%	Copper Fluoride	Kerosene	Potassium Chloride	Tanning Liquors
Arylsulfonic Acid	Copper Nitrate	Lactic Acid 28%	Potassium Chromate	Tartaric Acid
Barium Carbonate	Copper Sulfate	Lauric Acid	Potassium Cyanide	Titanium Tetrachloride
Barium Chloride	Cottonseed Oil	Lauryl Chloride	Potassium Dichromate	Triethanolamine
Barium Hydroxide	Cresylic Acid 50%	Lauryl Sulfate	Potassium Ferricyanide	Trimethyl Propane
Barium Sulfate	Crude Oil – Sour	Lead Acetate	Potassium Ferrocyanide	Trisodium Phosphate
Barium Sulfide	Crude Oil – Sweet	Lime Sulfur	Potassium Fluoride	Turpentine
Beet – Sugar Liquor	DeminerIALIZED Water	Linoleic Acid	Potassium Hydroxide	Urea
Benzene Sulfonic Acid 10%	Dextrin	Linseed Oil	Potassium Nitrate	Vinegar
Benzoic Acid	Dextrose	Lubricating Oils	Potassium Perborate	Whiskey
Bismuth Carbonate	Diglycolic Acid	Magnesium Carbonate	Potassium Perchlorate	White Liquor (Paper Industry)
Black Liquor (Paper Industry)	Disodium Phosphate	Magnesium Chloride	Potassium Permanganate 10%	Wines
Bleach – 12.5% Active CL ₂	Ethyl Alcohol	Magnesium Hydroxide	Potassium Persulfate	Zinc Chloride
Borax	Ethylene Glycol	Magnesium Nitrate	Potassium Sulfate	Zinc Chromate
Boric Acid	Fatty Acids	Magnesium Sulfate	Propane	Zinc Cyanide
Brine	Ferric Chloride	Maleic Acid	Propyl Alcohol	Zinc Nitrate
Breeder Pellets – Dane. Fish	Ferric Nitrate	Malic Acid	Silicic Acid	Zinc Sulfate
Bromic Acid	Ferric Sulfate	Mercuric Chloride	Silver Cyanide	
Bromine – Water	Ferrous Chloride	Mercuric Cyanide	Silver Nitrate	
Butane	Ferrous Sulfate		Silver Plating Solutions	
Butadiene			Sodium Acetate	

Suggested Format for Specifying Carlon Nonmetallic Conduit, Conduit Fittings and Junction Boxes

- A.** The Carlon rigid nonmetallic conduit system shall be installed as indicated on the drawings and as specified herein.
- B.** All wiring shall be installed in Carlon rigid nonmetallic conduit. All conduit shall be secured by means of proper fittings. All fittings shall be Carlon.
- C.** Carlon outlet boxes, fittings and junction boxes shall be used for all outlets, pull boxes and junction points. (Lighting fixtures shall not be supported or hung from PVC junction boxes but be supported in position by other means.)
- D.** Exposed conduits shall be mounted securely by suitable hangers or straps with the maximum spacing of points of supports not greater than indicated by Section 352.30 of the NEC.
- E.** Except where embedded in concrete or direct buried, Carlon conduit shall be supported to permit adequate lineal movement to allow for expansion and contraction of conduit due to temperature change.
- F.** For aboveground installations where temperature change in excess of 14°C (25°F) is anticipated, expansion joints shall be installed. See Table 352.44(A) NEC for expansion characteristics.
- G.** Proper care shall be taken when field bending is employed to maintain the internal diameter and wall thickness of the conduit.

